





SPAD

Simple Plastic Airplane Design



-  S.P.A.D.
-  SPAD Index
-  Materials
-  Build
-  Fuse
-  Tail
-  Tail Photos
-  Fuse Servo
-  Engine
-  Tail wheel
-  Wing
-  Wing finish
-  Final
-  Dihedral1

SPAD BUHOR Big Ugly Hell on Rails



The SPAD Big Ugly Hell On Rails (BUHOR?) is the simplest larger brother of the HOR and equally simple to build. Plus it takes care of the problem of the dimenishing supply of PVC downspout worldwide as it seems everyone can find almuninum angle. Of course it retains the great flying characteristics we've all come to love with absolutely NONE of the looks. Take an hour and build one, we promis you'll be satisfied..

Type: Sport Fun

Wingspan: 60"

Length: 48"

Engine: .40 to as much as you dare!

Channels: 4 - Elevator, Ailerons, Rudder & Throttle



[[SPAD Index](#)] [[Materials](#)] [[Build](#)] [[Fuse](#)] [[Tail](#)] [[Tail Photos](#)] [[Fuse Servo](#)]

For .40 - .47 size engines



60" Wingspan

For lazy sport and advanced training



Rot-gut bare bones simplicity and just plane fun! Big wing, low wing loading, slow and very smooth floater! This airplane is perfect for training and relaxing sport flying. Please **DO NOT** overpower this plane or expect a sky burner, as you may consider the aluminum fuselage too flexible. This essay is presented as exactly how I built mine. **PLEASE** don't hesitate to change, modify and experiment with these ideas! *Tattoo*

Materials

- 8 feet long x 1/16" thick x 3/4" x 3/4" Aluminum "L" Channel for fuselage
- 4mm Coroplast for wing and tail
- 2 standard cheap yardsticks for spar
- Wal-Mart POLY kitchen cutting board for engine mount
- 1/8" thick x 1" wide aluminum stock for landing gear (I used a 20" long piece)
- Fourteen 6-32 x 3/4" bolts with fiber lock nuts for fuselage build
- Two 6-32 x 1 1/2" bolts and four fiber lock nuts for wheel axles
- Nine #6 x 3/4" self tapping screws for tail and engine mount mounting
- One 1 1/4" long deck screw for engine mount mounting
- 2 3/4" diameter main wheels
- 1" diameter tail wheel
- 3 /32" wire for tail wheel
- Regular zip-ties (servo mounting) and small zip-ties (for wires)
- Double sticky foam mounting tape (for servo mounting)
- PVC gutterpipe scraps for control horns/back plates and tail mount doublers
- Coat hanger for throttle pushrod
- Small self tapping screws for engine, tail wheel block and control horn mounting
- Your engine, fuel tank and tubing, radio equipment, clevises and pushrods
- #64 rubberbands
- Propane torch, windex, water spray bottle and medium CA for wing building
- 2 x 4 wood and clamps for wing building
- Foam for under fuel tank, and around battery and Rx
- Hack saw, sharp drill bits, and standard shop tools
- If you have a band saw, or access to one...it will help for cutting out engine mount

Page 2-Big Ugly Hell On Rails-Building Instructions

1. Build the fuselage from 8' of 3/4" aluminum "L" channel. Cut it into two 4' pieces, then cut two 2 1/2" pieces off each one. This will give you two 43" sides and four 2 1/2" cross braces. Drill holes and bolt together as shown on page 3 with 6-32 bolts and fiber lock nuts.
2. Cut a 3" x 4" rectangle out of a Wal-Mart POLY cutting board. A band saw works best for this. GO SLOW because the plastic likes to melt and gum up. Make an engine cut-out the size needed for your engine. Drill holes and mount it to your fuselage using three #6 x 3/4" self tapping screws and one 1 1/2" long deck screw as shown on page 3. The deck screw will protrude below the engine mount and provide a place for your fuel tank rubber bands to ancor. Exact screw location is not critical...but MAKE SURE engine mount is straight.
3. From the cutting board piece you cut out for your engine, make a 1" x 3/4" tail wheel block. Drill holes and screw it to the aft cross brace with small self tapping screws.
4. Cut out 4mm tail pieces and PVC gutterpipe pieces as shown on page 4. Drill holes and mount tail pieces to rear of fuselage with #6 x 3/4" self tapping screws, using PVC doublers for screws to self tap into. Tighten until Coroplast just starts to smunch a little. Exact screw location is not critical, but MAKE SURE the tail pieces are straight and the hinges clear the end of the fuselage. Use reference photos for tail mounting & for general location of control horns and mount them as close as possible to the hinges. CA can be used to tack the horn in place while installing the screws.
5. Drill out tail wheel to 3/32". Drill 3/32" hole in tail wheel block. Bend small "L" on end of 6" long piece of 3/32" wire and slip tail wheel on other end and up to "L". Study reference photos and proceede to bend tail wheel wire, then put through tail wheel block, then bend over, and finish with Z-bend.
6. Build wing from 4mm coroplast as shown on the wing drawing. Leading edge score is made on the INSIDE of the wing using a small blunt tipped object and a straight edge. Flip over and fold leading edge over a straight table edge. ALL AREAS TO BE GLUED MUST BE CLEANED WITH WINDEX AND FLASHED. USE A PROPANE TORCH AND RUN IT OVER THE PLASTIC TO BURN THE MANUFACTURING OILS OUT OF IT. YOU WILL SEE VERY LITTLE INDICATION OF HAVING DONE ANYTHING. IF THE PLASTIC STARTS TO RIPPLE A LITTLE DON'T WORRY, IT'S THE INSIDE THE WING AND YOU KNOW YOU'VE FLASHED IT GOOD...JUST DON'T BURN IT! Use a bead of glue when gluing the spar down and you can use a water mist as a kicker. WHEN GLUING THE TRAILING EDGE, WING WRAP AND AILERON PIECES, ONLY USE ROWS OF CA DROPS 1/2" APART AND A DROP EVERY 1/2". After applying the glue and just before mating the pieces SPRAY A LIGHT WATER MIST ON THE OPPOSING GLUE SURFACE. Don't let the pieces move at all after initial contact! Practice on some scrap first...if done correctly, your glue joints should be cured within several minutes. **Using too much glue is the BIGGEST mistake when gluing coro to coro!**
7. Any good .40 sized landing gear will work fine. Mine is made from 1/8" x 1" x 20" long aluminum stock and it was rolled into it's shape on a roller at my work. Bending it at conventional angles in a vice would work just fine also, just make sure your finished gear have the wheels at least 12" apart and hold the plane at least 6" or more from the ground. You will not mount the gear to the plane until everything else is finished and after the plane has been balanced.
8. Study and follow the reference photos for radio and engine installation. When your radio equipment and engine are all installed, and the ONLY thing left to do before going flying is mount the wing rubber band hold down bolts and landing gear...please proceede to the "finishing" page of this essay.

Page 3- Big Ugly Hell On Rails-Fuselage

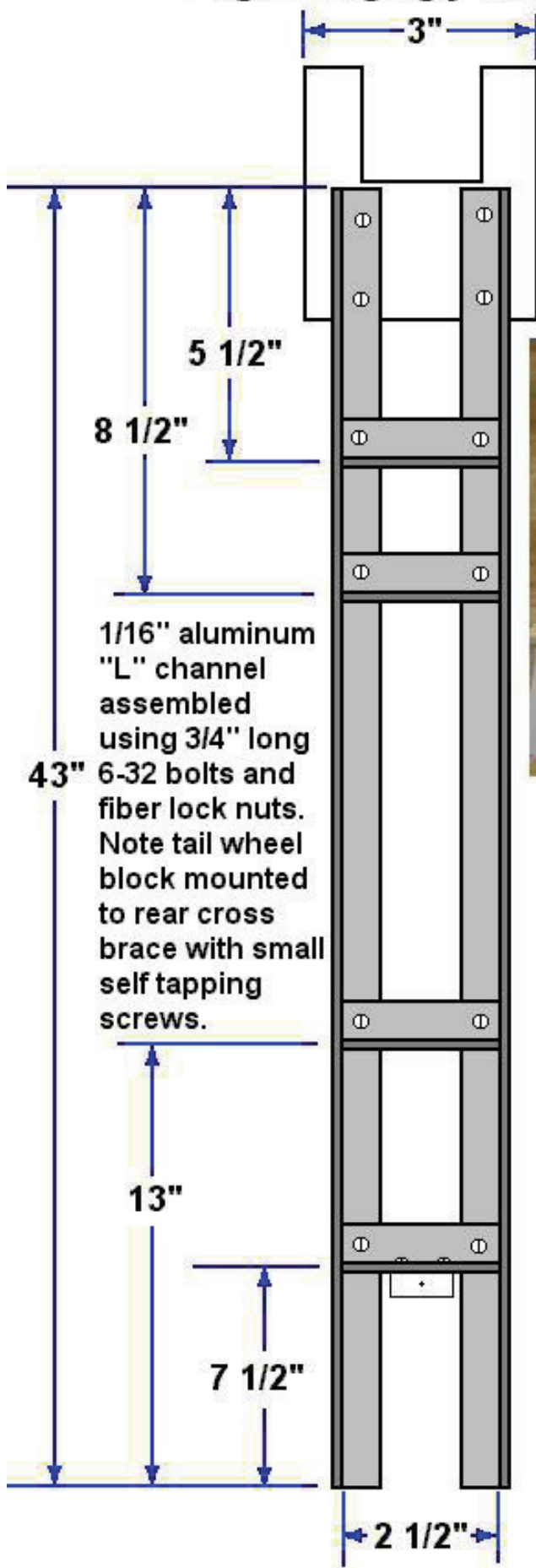

Make sure you get a cutting board with POLY on the label. The good ones are milky white in color and you can sort of see through them. They grab self tapping screws like crazy, and I don't even drill pilot holes anymore...just go for it!

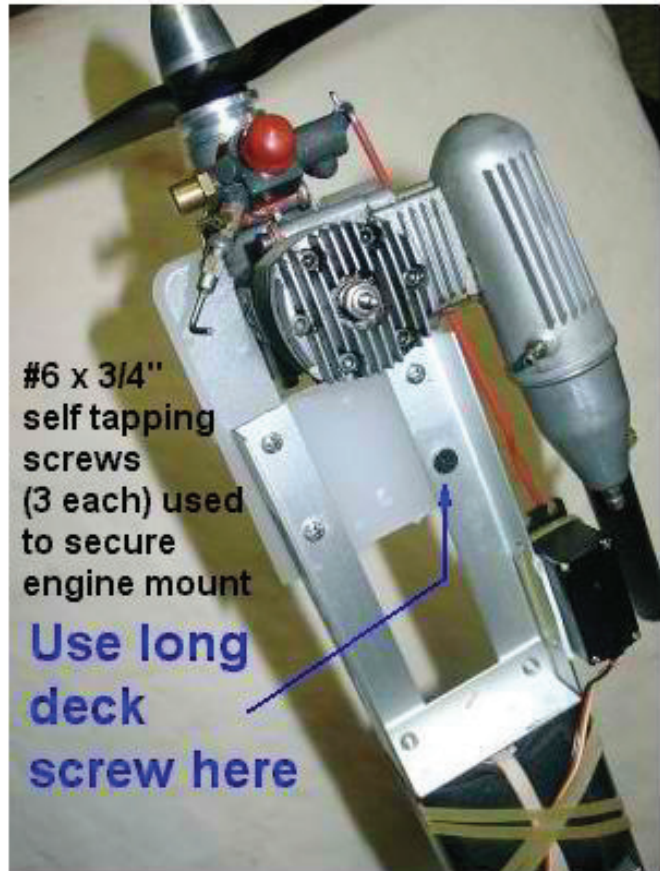

1/16" aluminum "L" channel assembled using 3/4" long 6-32 bolts and fiber lock nuts. Note tail wheel block mounted to rear cross brace with small self tapping screws.

#6 x 3/4" self tapping screws (3 each) used to secure engine mount

Use long deck screw here

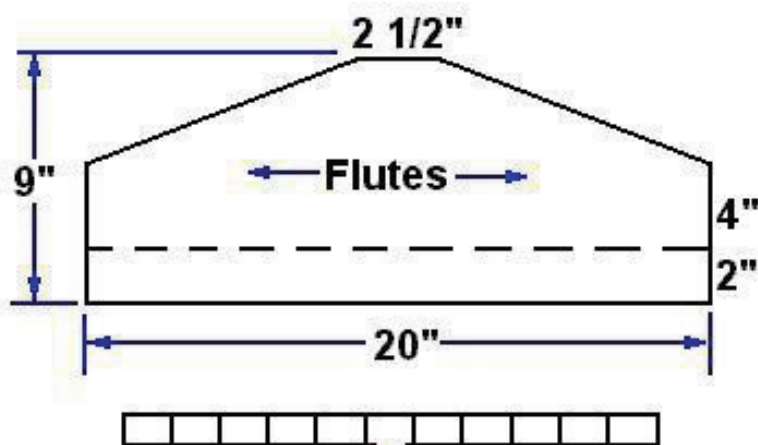

Hinge on dotted line by cutting away one side of a Croplast flute as shown above.

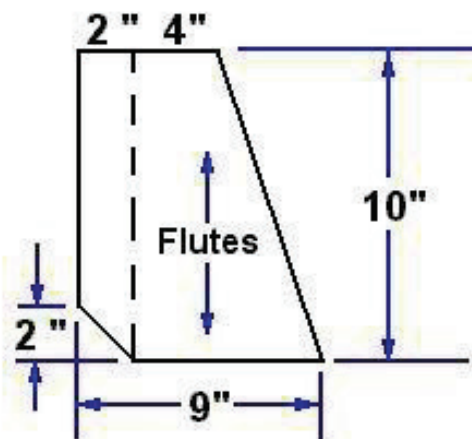

Cut the tail pieces from 4mm Coroplast as shown above. Make the PVC gutterpipe pieces as shown here. Tin snips is a great tool for cutting out PVC pieces. Drill the clevis hole in the control horn the size of your clevises. Drill the screw holes in the horns large enough for your small self tapping screw to pass through. Drill a very teensy small dinky pilot hole in the control horn back plates and tail mount doublers so that they will grab the self tapping screws real good. Drill the holes in the aileron zip-tie doubler the width of your aileron servo, and large enough for your zip-ties to go through. Drill holes and mount the tail feathers to your plane with #6 x 3/4" self tapping screws. Make sure they are straight and the hinges clear the end of the fuselage. Install your control horns as close to the hinge as possible using small self tapping screws. I used #4 x 1/2" screws for my control horns but anything small is fine. A couple drops of CA will tack PVC parts in place real nice for drilling and installing screws.

PVC Gutterpipe Parts



Control Horn (make 4)

Control Horn Back plate and Vertical stab doublers (make 6)

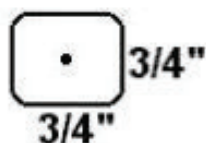

Horizontal stab doublers (make 2)



Aileron Zip-Tie Doubler (make 1)



Page 5- Big Ugly Hell On Rails- Reference Photos

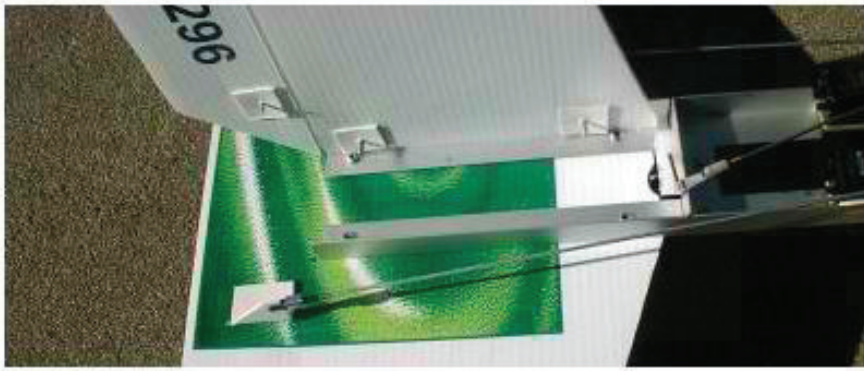

Vertical stab is mounted on the inside of the left fuselage rail. Make sure the rudder hinge clears the end of the aluminum channel.

When tightening up the screws, only go until you see the PVC start to sink in and the Coroplast smunch just a little bit.

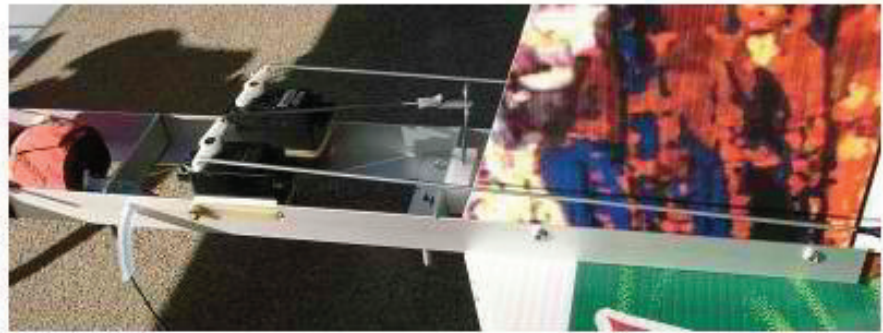

Make sure the elevator hinge clears the end of the aluminum channel and the tail is lined up square with the fuselage. This picture also shows the tail wheel and tail wheel block. Notice that I had to trim some of the horizontal stab to clear the tail wheel...you won't have to do that because I moved the cross brace up a half inch on the fuselage drawing.



Page 6- Big Ugly Hell On Rails- Reference Photos

The elevator and rudder servos are mounted with double sticky foam mounting tape and zip-ties, in between the rear cross braces. Mark and drill for zip-tie holes BEFORE sticking servo in place. Also drill holes for antenna fuel tube housing. Once antenna is clear of the fuselage, simply run it down a flute of the horizontal stab.

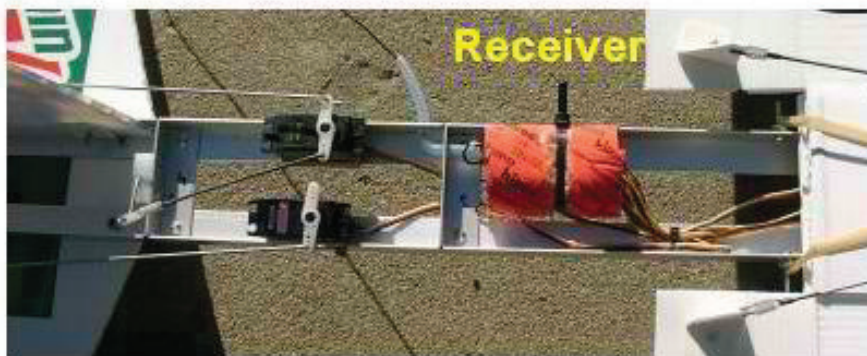
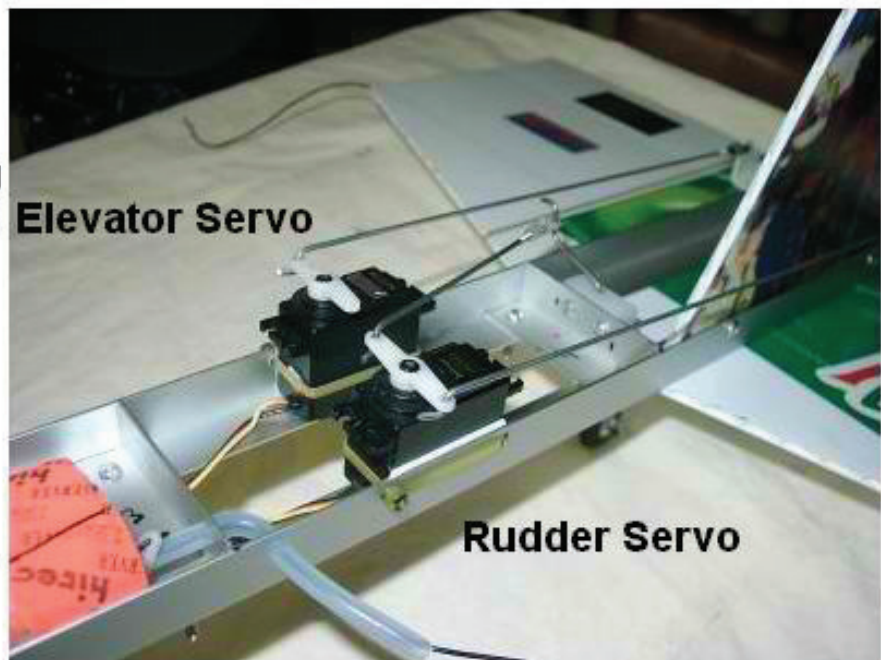

The receiver is simply zip-tied to the side of the channel. Also drill small holes and use small zip-ties to secure the servo wires wherever you think you need them.

I didn't use a switch for this airplane. I simply ran an extension lead up to just behind the battery. I just plug it in for "ON" and un-plug it for "OFF" ...it doesn't get any simpler than that!!!

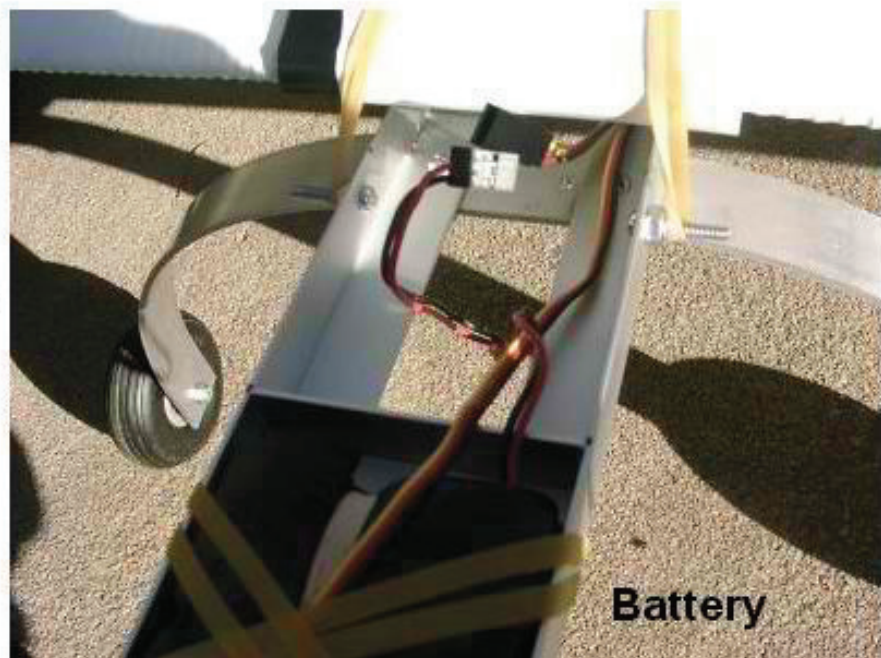

Page 7 - Big Ugly Hell On Rails- Reference photos

I mounted the engine to the **BOTTOM** of the engine mount so I wouldn't have to remove the muffler to install it. I used #4 x 1/2" self tapping screws. I didn't even use pilot holes...and they are nice and tight! The throttle servo is mounted upside down with double sticky foam tape and a zip-tie. I stripped the coating off the ends of some coat hanger and used that for the throttle push-rod with Z-bends in each end.

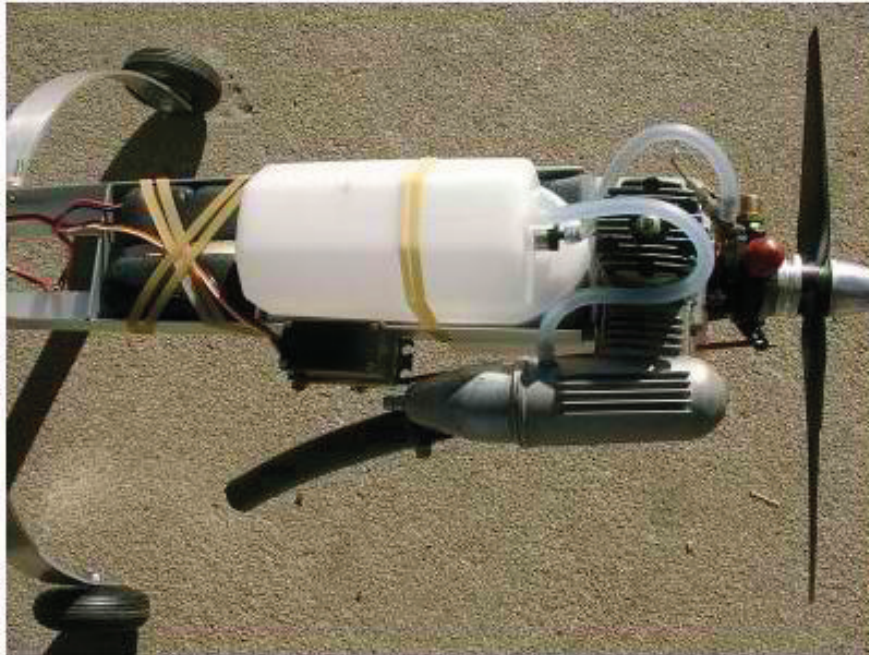
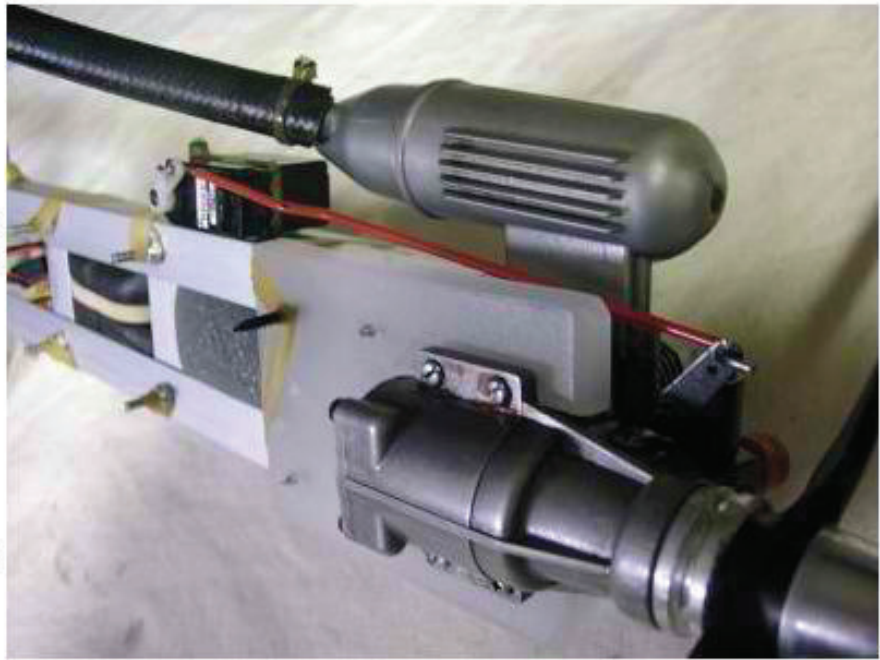

Note that the throttle servo is upside down and on the outside of the aluminum rail. Use foam under the fuel tank, and install it using rubberbands around the long engine mount deck screw. Make sure you use foam around your battery, and rubber band it in place using the cross brace studs.

The last step of building this plane will be installing the landing gear. Look close at the picture above and you can see that the wheels "toe-in" towards the front of the airplane. This is very important! Also note the exhaust extension I made with some automotive fuel tubing and a zip-tie.



Page 8- Big Ugly Hell On Rails - Reference photos

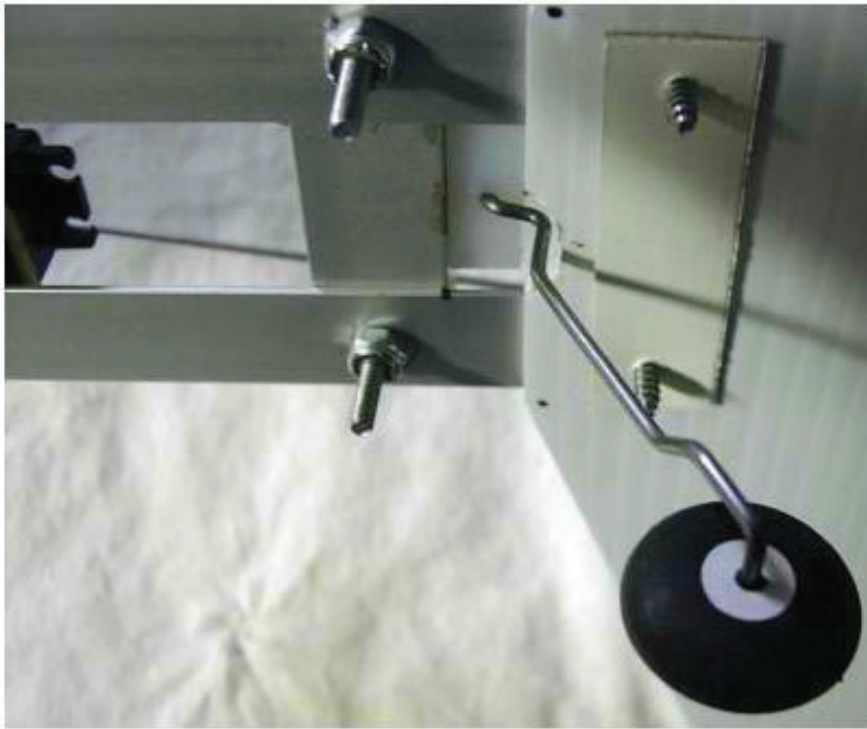

My goal was to make a tail wheel without using any collars. Bend a small "L" at the end of 6" of your wire and slip the wheel on the other end and all the way up to the "L" you bent. Now make the bend shown on the other side of the wheel, then above the wheel, and then a Z-bend at the bottom of the tail wheel block. Drill the block out to the size wire you're using (I used 3/32") and slide the wire into the hole.

After inserting the tail wheel wire through the block, bend the wire over, and finish it off with a Z-bend. Simply cut the pin side of a nylon clevis off, and use the other side slipped over the Z-bend.

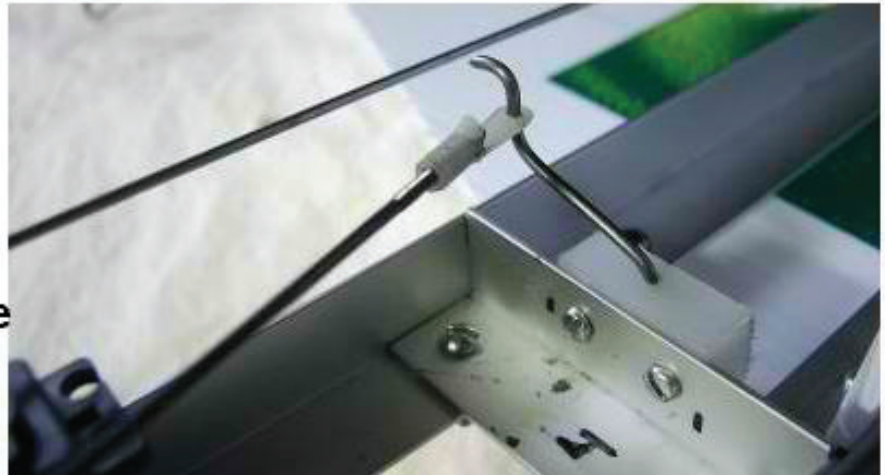

For my axles I simply use 6-32 x 1 1/2" long bolts and 2 self locking nuts. Put the bolt through the wheel and run a nut to where it almost touches the wheel. Then drill the hole in the gear, and install your wheel with the second self locking nut.

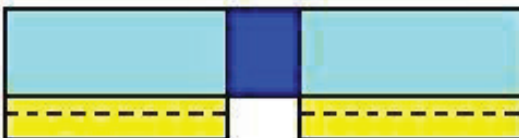
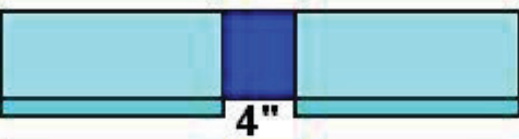
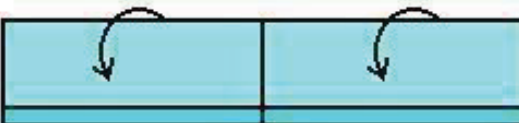
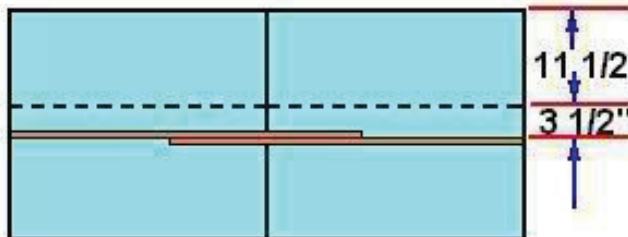
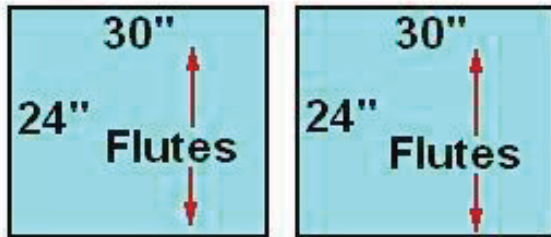
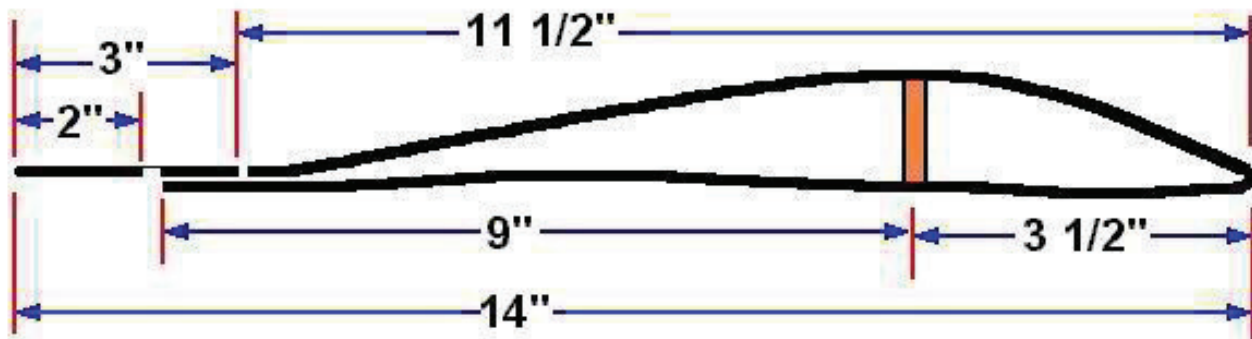

Start with two pieces of 4mm coroplast. Make a 60" spar by lap jointing two standard yardsticks. Score leading edges with small dull pointed object (I use a #1 phillips screwdriver) and pre-fold over the edge of a table. Butt panels together and glue spar in place. Working one side at a time, fold and glue top wing panels to spar and trailing edge. Picture below show how I do it with 2 x 4's, some clamps and 3 thick yardstick shims under leading edge 2 x 4. After glue sets, trim bottom panel trailing edge lip to 1" if it isn't already. Cut 4" out of bottom panel lip at wing center. Glue 4" wide wing center wrap around wing center. FLUTES IN CENTER WRAP AND AILERON PIECES GO SPANWISE. Cut out 3" x 28" aileron pieces and glue to lower wing panel lip. Hinge ailerons by cutting away the bottom of the first unobstructed flute. Insert a dowel or some scrap rod or coat hanger in leading and trailing edge flute of wing wrap for rubberband protection.

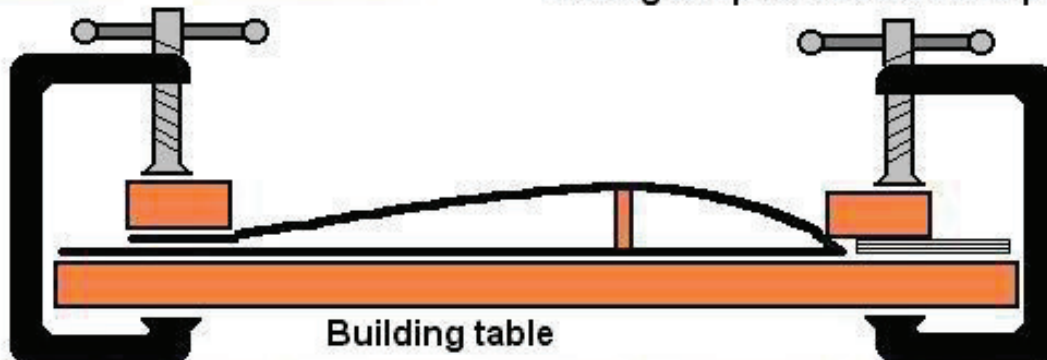

Building table

Please note that when folding coroplast and forming airfoils, measurements may vary slightly and may not be exactly as shown. Once the pressure is let off, the leading edge may rise slightly and the bottom of the trailing will undercamber beautifully. When using this wing design, balance your aircraft's CG directly at the spar.

Page 10- Big Ugly Hell On Rails- Reference Photos

Make sure that when you balance your plane, it balances perfectly level when picked up with a finger tip directly under the wing Spar!



I used a black zip-tie so it's hard to see, but it's there around the top of the aileron servo, and then runs through to the bottom of the wing and then is pulled tight utilizing the PVC zip-tie doubler. Also note the hole for the aileron servo lead just behind the servo. If you look close at the wing wrap in the above picture, you can almost see that I put scrap coat hanger in the leading and trailing edge flutes on top for rubber band protection.

Note that the aileron control horns are installed at a slight angle, and as close to the hinge as possible. Cut a hole in the wing center, just aft of the spar for a snug aileron servo fit, and then install the servo using a zip-tie and the PVC zip-tie doubler on the bottom of the wing

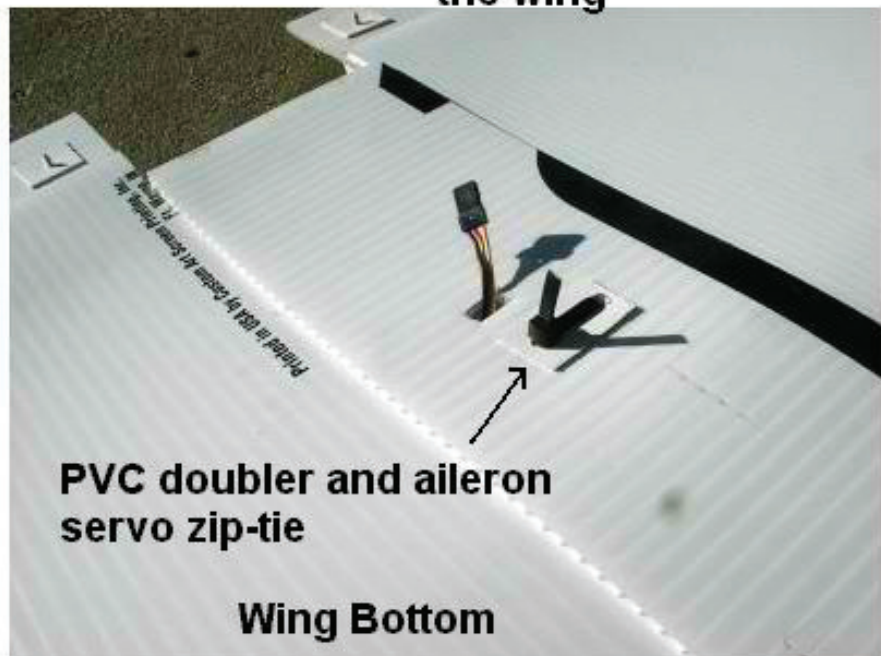



Make sure EVERYTHING is done and installed except the landing gear and wing hold down bolts. Rubber band two scrap dowels (or even pencils would be fine) under the fuselage in the approximate locations of the hold down bolts. Lay the landing gear across the top of the fuselage, and then install the wing on top of

them using rubber bands and the dowels. Position the leading edge of the landing gear to be even with the leading edge of the wing, and position the wing on the fuselage until the plane balances perfectly level AT THE WING SPAR. Mark the wing leading and trailing edge locations on the fuselage. Remove wing. Drill holes and install wing hold down bolts and nuts 1/4" forward of leading edge marks and 1/4" rear of trailing edge marks. Drill holes and mount landing gear to bottom of fuselage with landing gear leading edge even with wing leading edge marks.

Look close at the picture above and you can see that the main wheels are "toed-in" towards the front of the plane. Make sure your wheels have several degrees of "toe-in" in them to help your plane track straight for take off...THIS IS VERY IMPORTANT on all tail draggers! Check the travels on your control surfaces. The ailerons should have about 3/4" travel each way (1 1/2" total) and the rudder and elevator should have about 1" travel each way (2" total). Travel is checked by simply holding a ruler up to the trailing edge of the control surface and operating them. Make sure that when your wing is strapped to the fuselage the ailerons are PARALLEL to the fuselage in the neutral position. If they are drooping at all, your airplane may have pitch trim problems. Make sure that your antenna doesn't touch any part of the aluminum fuselage or radio wires, or you might get interference. Make sure your throttle has full travel from kill to full open, and make sure your throttle servo doesn't hum from trying to move the throttle further than is physically can, or you might get a higher than normal battery drain. Make sure you put a small piece of fuel tubing on each clevis to prevent them from popping open. Use at least 6 per side (12 total) rubber bands to hold the wing on, two on each side (4 total) to hold the battery in, and 2 to hold the fuel tank on. Follow all AMA safety guidelines, and have FUN!!! If you've never flown before GET HELP OR YOU WILL CRASH! GUARANTEE! If you have questions or further comments, please visit a Spad forum link at www.spadtothebone.com





Building a dihedral wing for the Big Ugly Hell On Rails

Page 2

All 4mm Coroplast used in wing construction

Wing Span- 60"
Wing Chord- 14"



Adding 5" of dihedral to the Big Ugly Hell On Rails wing will give it the self righting characteristics of a good trainer. With a wing loading of 15.9 oz./sq. ft. the prototype rivals any trainer on the market for slow and forgiving flight characteristics!

**Here are the parts to build your wing:
two 24" x 30" wing halves
two 3" x 28" ailerons
one 4" x 24" wing wrap
two Standard yardsticks**

Page 3



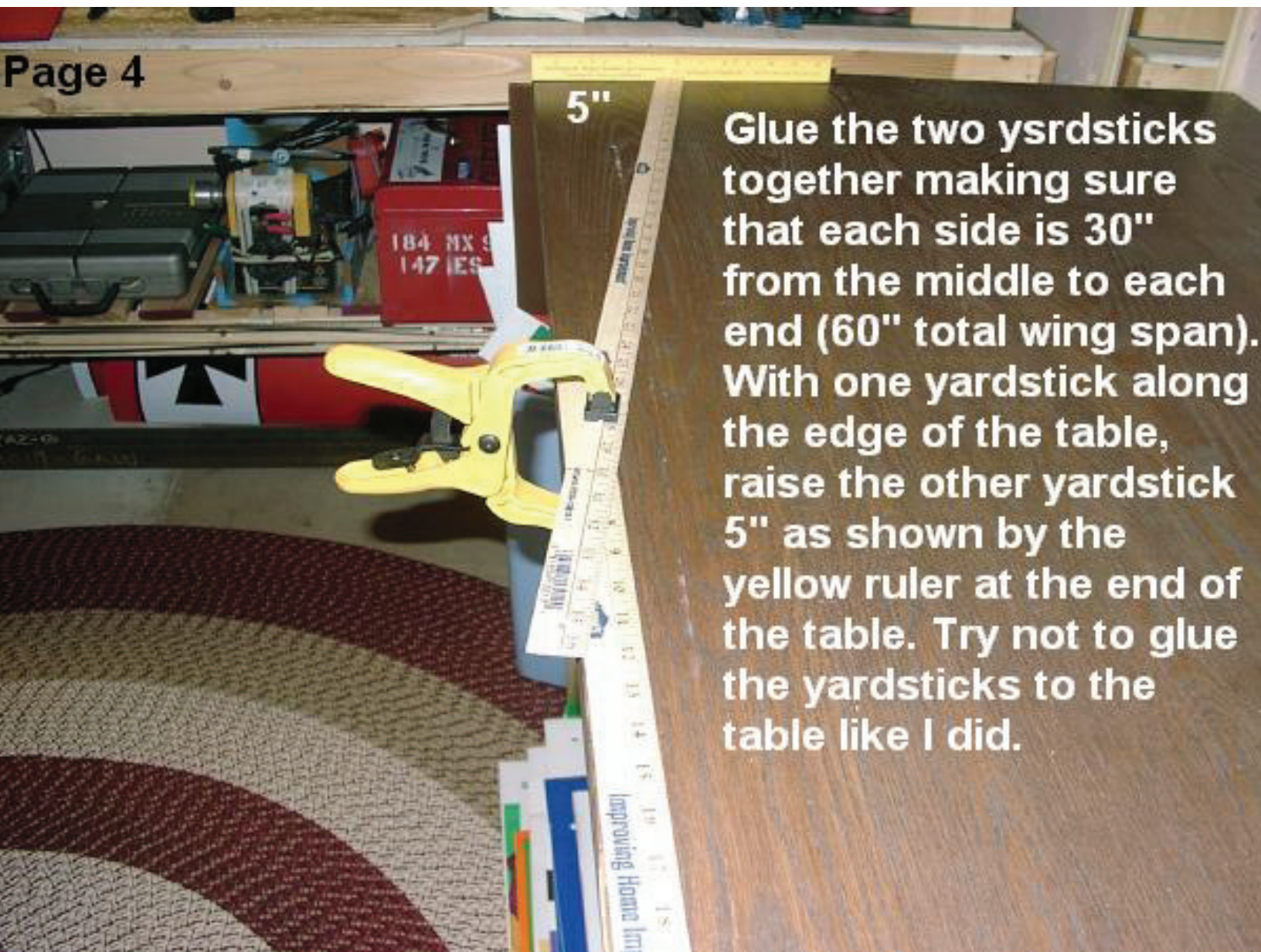

5"

Glue the two yardsticks together making sure that each side is 30" from the middle to each end (60" total wing span). With one yardstick along the edge of the table, raise the other yardstick 5" as shown by the yellow ruler at the end of the table. Try not to glue the yardsticks to the table like I did.

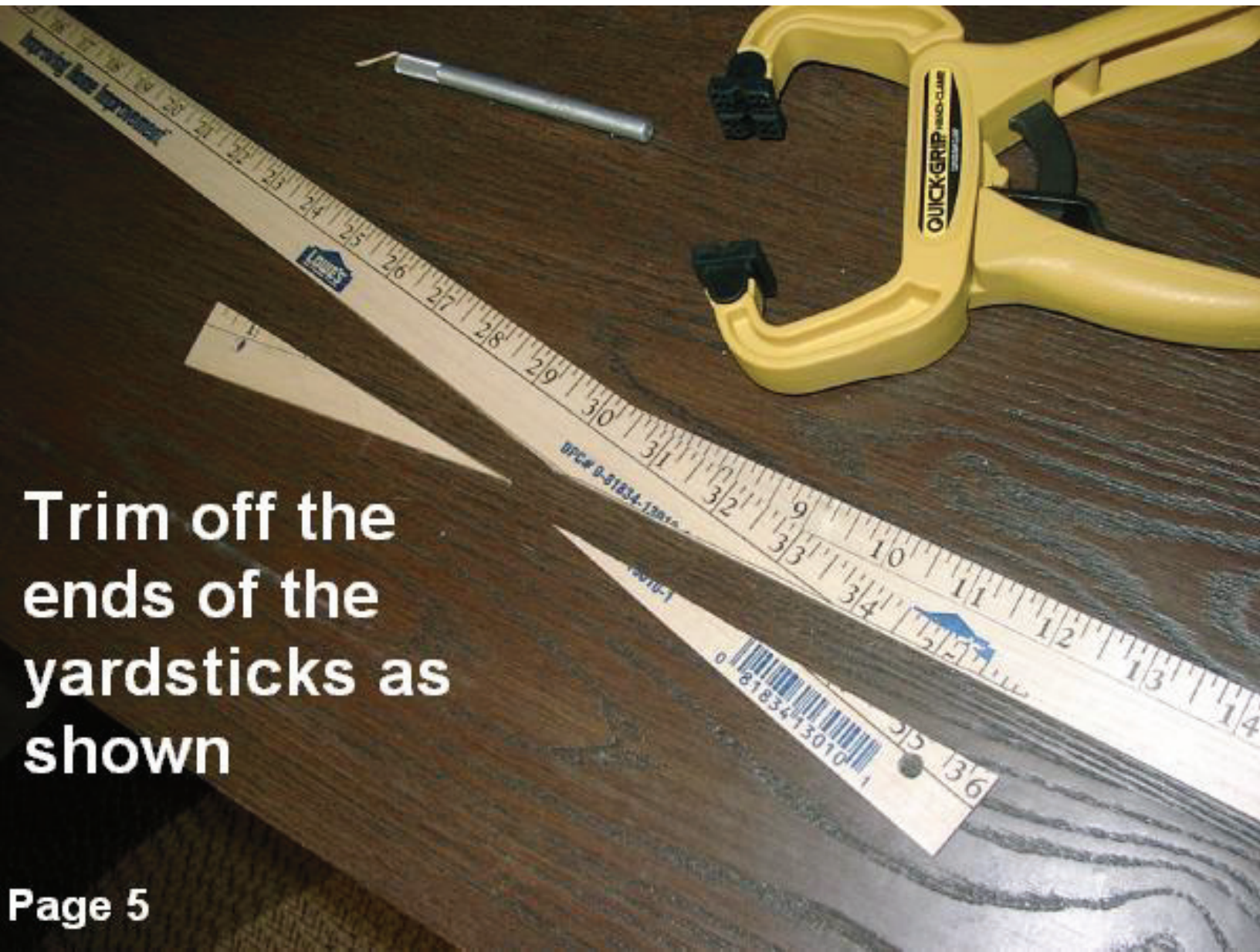

Trim off the ends of the yardsticks as shown

Page 6

Take the pieces you trimmed off from the bottom, flip them over and glue in place as shown, to give the spar center section extra strength.



Mark the leading edge fold line (dotted) and the spar glue line on your wing halves

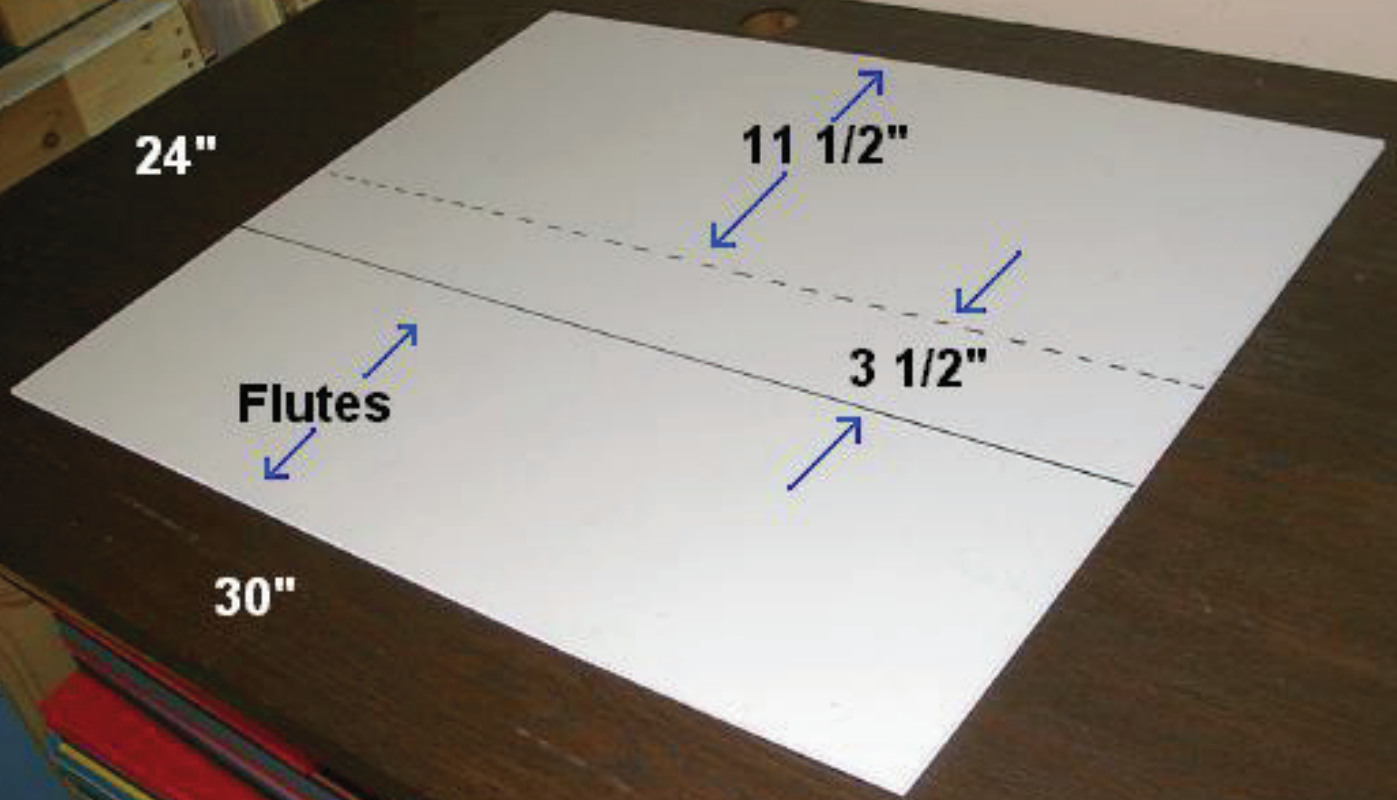

Use a straight edge and small phillips screwdriver to score the leading edge fold line several times.



Flip the wing half over and fold the leading edge over the side of a table



All glue joints must be cleaned with windex and then flashed with a torch. Flash the spar glue line and don't worry if the plastic ripples a little...heck...it's the inside of the wing. This will burn the oils out of the plastic and allow the glue to hold.

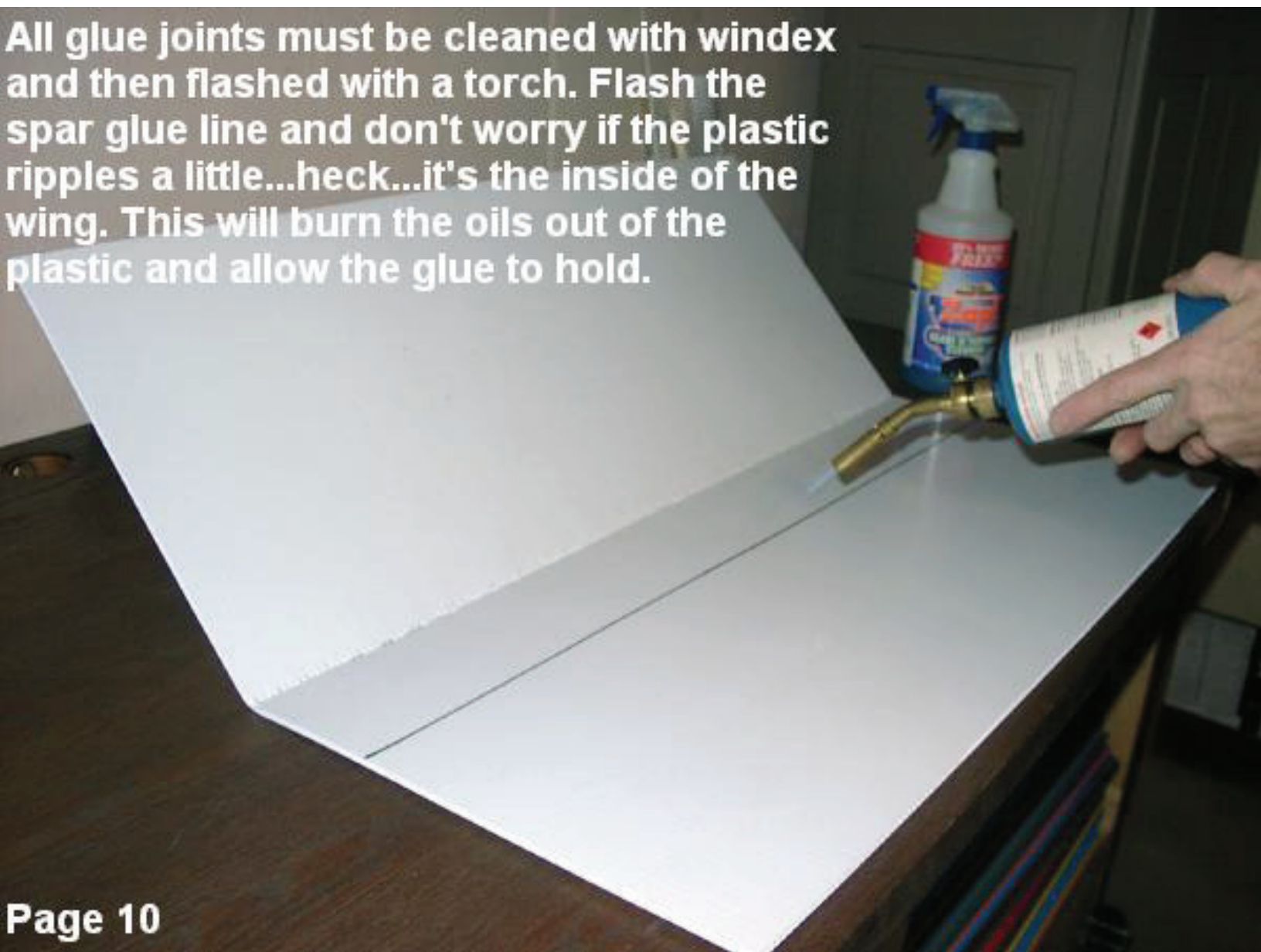

Use a bead of medium CA on the spar and spray a very light water mist on the Coroplast and glue the spar in place as shown. Then clean and flash where the trailing edges will meet and where the top panel will meet the spar

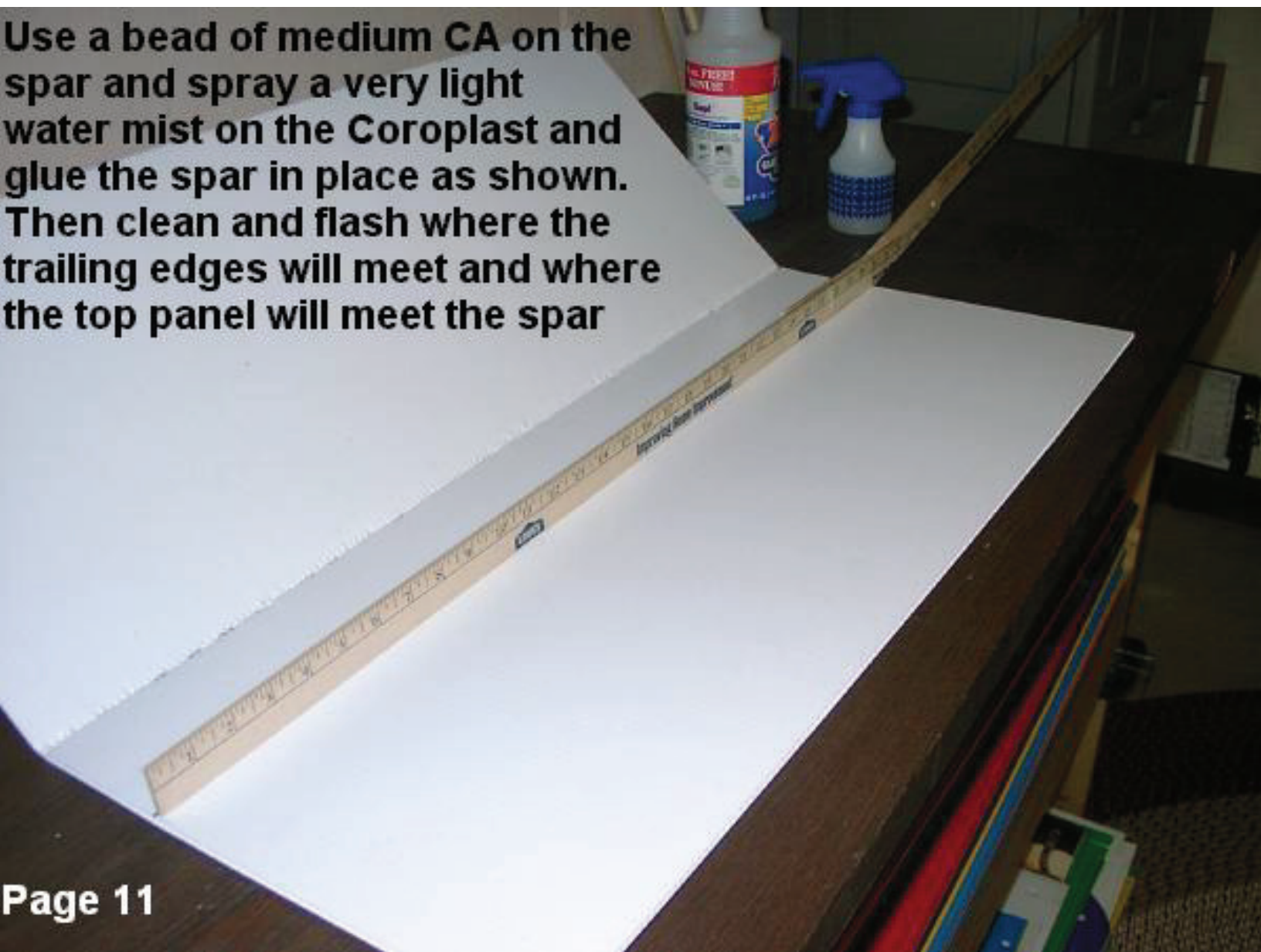



Fold the wing over and glue to the spar and trailing edge. Use a bead of glue on the spar and two rows of dots every 1/2" on the trailing edge. This picture shows how I keep the leading and trailing edges down.

Don't forget to spray water mist on the opposing glue surfaces!

Follow the same process for the other wing half. You will have to trim the center top panel where they meet, but you don't have to make it pretty because it will be covered by the wing wrap later



Glue this half just like you did the first half.



Trim 4" out of the center bottom panel, and trim the bottom overhang to 1" wide if it isn't already



1"



4"

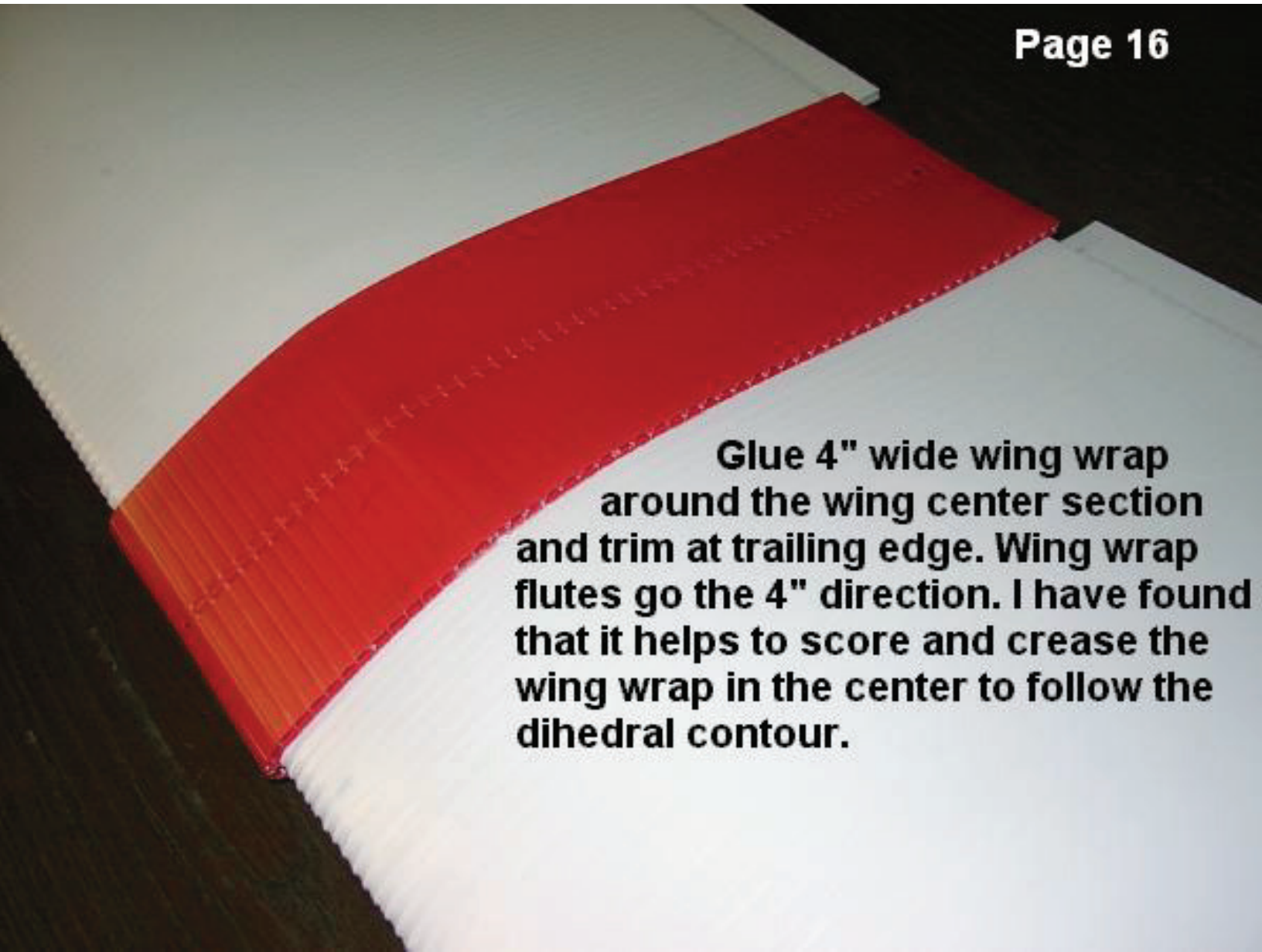

Glue 4" wide wing wrap around the wing center section and trim at trailing edge. Wing wrap flutes go the 4" direction. I have found that it helps to score and crease the wing wrap in the center to follow the dihedral contour.

Glue the ailerons in place on the lower wing panel overhang. Don't forget to clean and flash!

28"

3"

Flutes

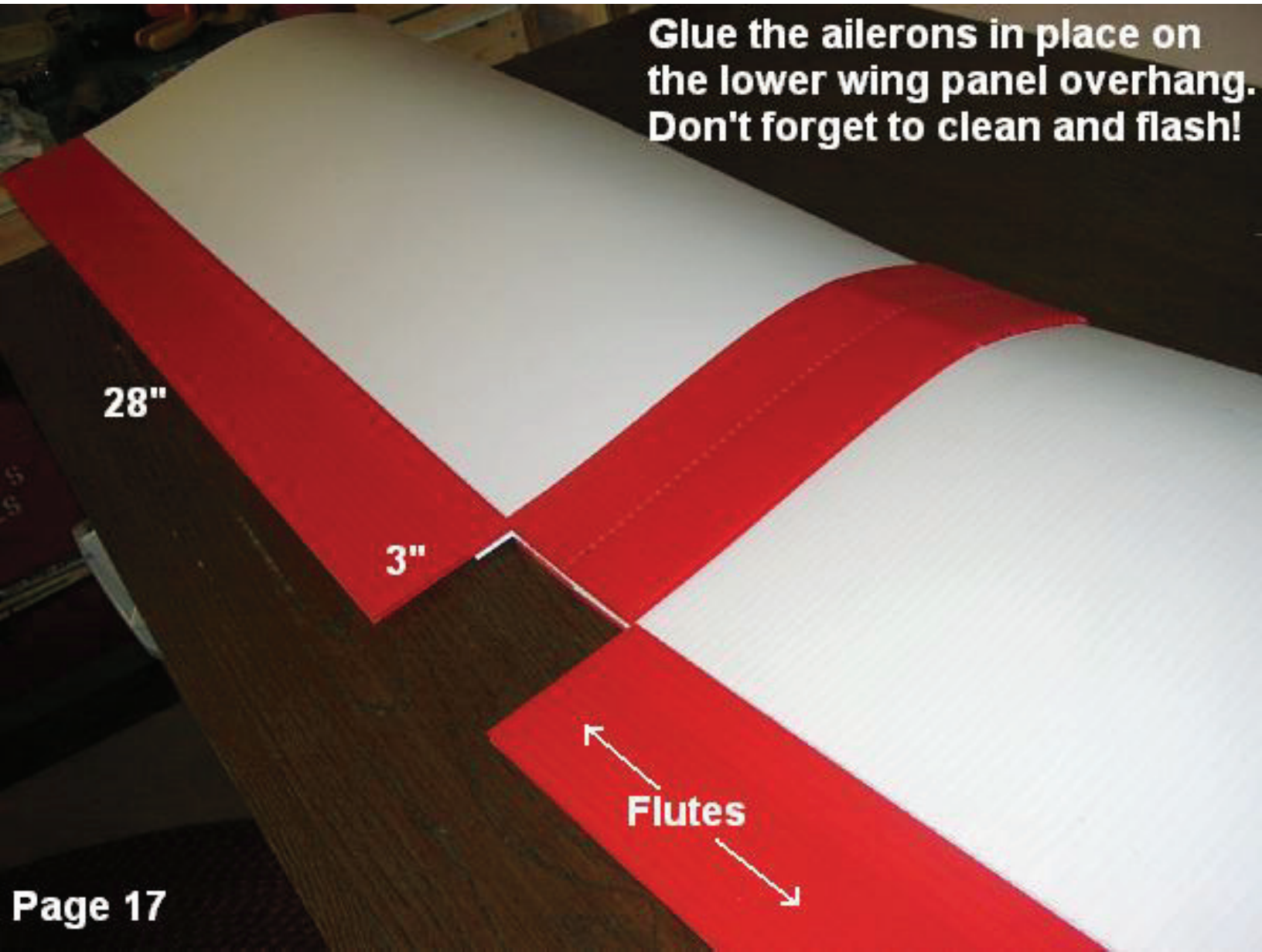

Page 18

Turn the wing over and hinge the ailerons by cutting away the bottom of the first unobstructed flute.

Wing Bottom

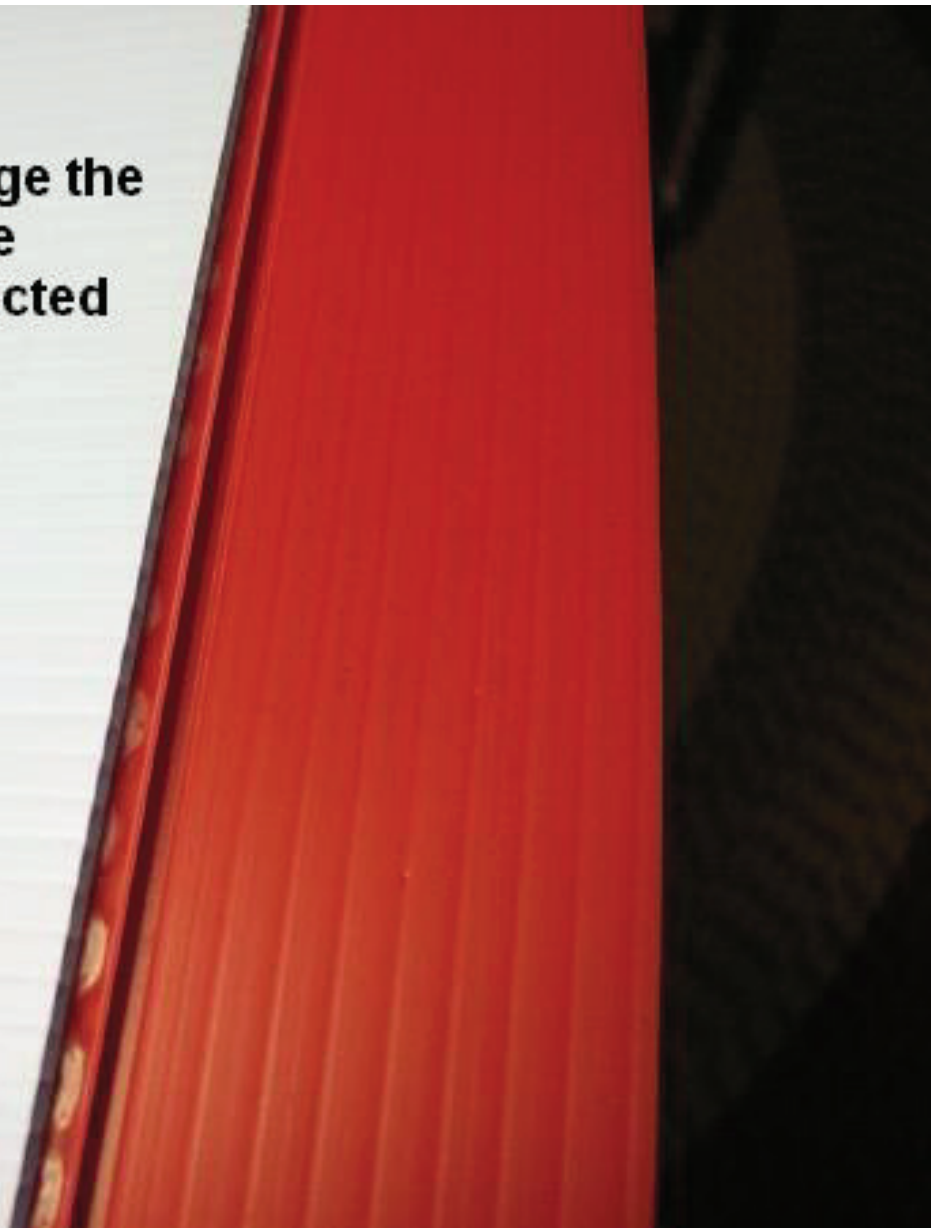

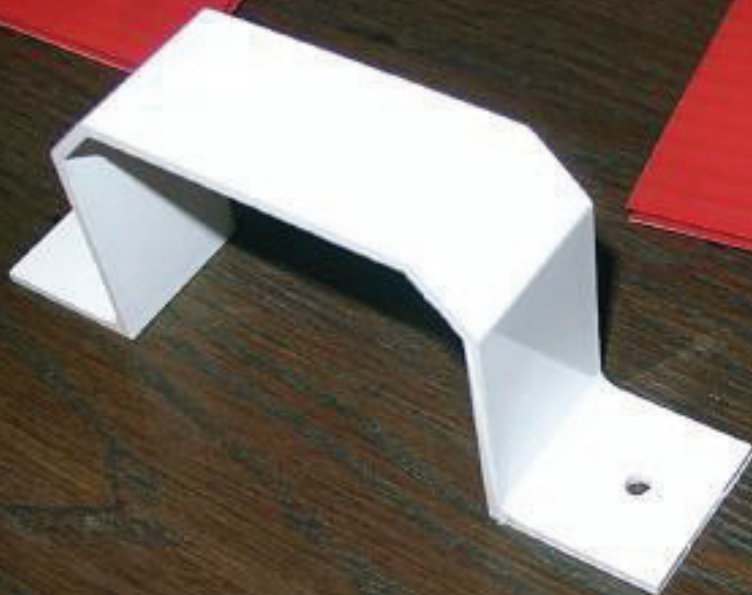

I found this PVC bracket at **LOWES** for 89 cents in the gutter-pipe area.

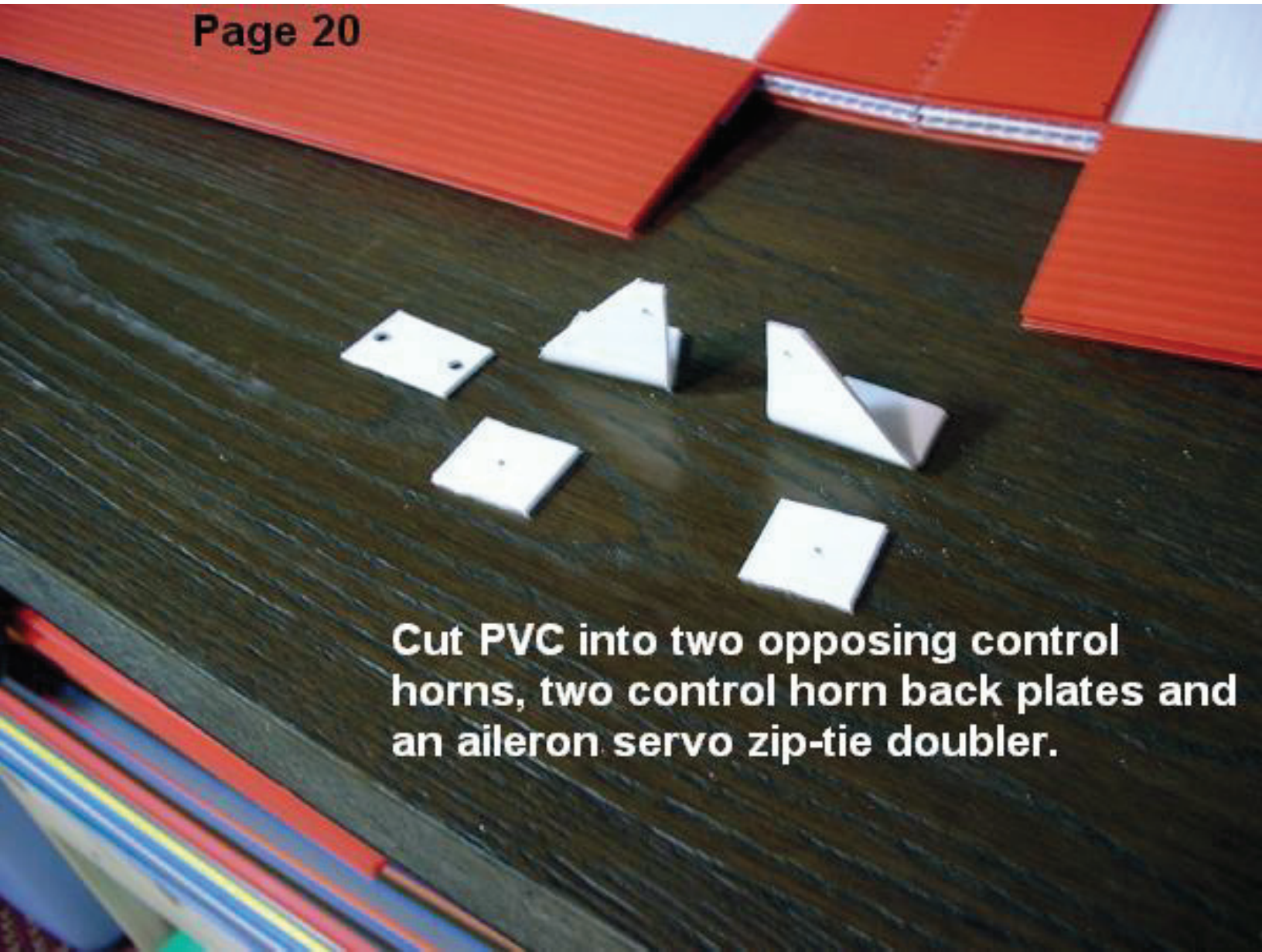

Cut PVC into two opposing control horns, two control horn back plates and an aileron servo zip-tie doubler.

Install control horns at a slight angle and as close to hinge as possible. Cut the aileron servo hole for a snug fit.

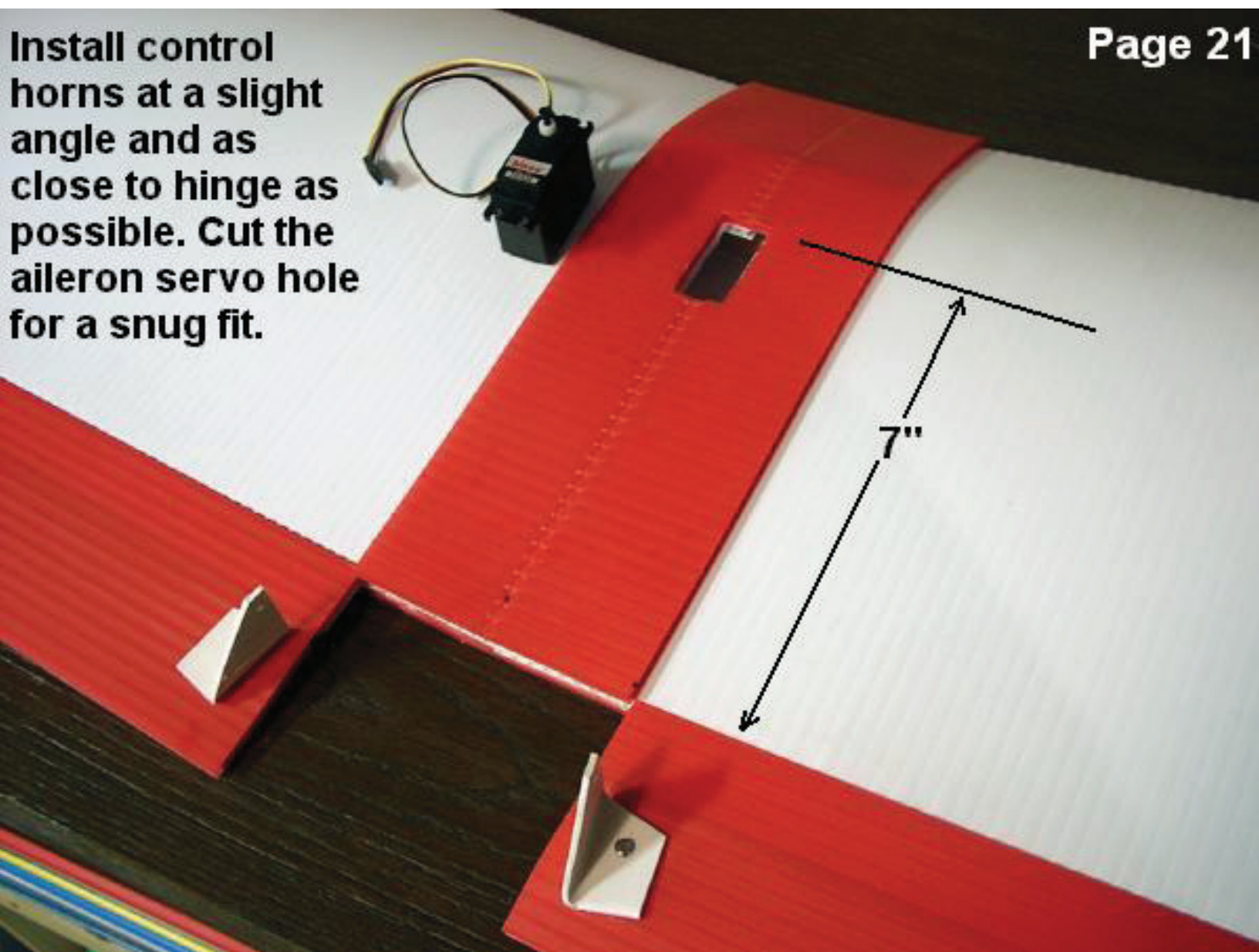

Drill two zip-tie holes directly below the aileron servo hole, in the bottom of the wing and cut a small hole rear of the servo hole for the aileron servo lead.

**Wing
Bottom**

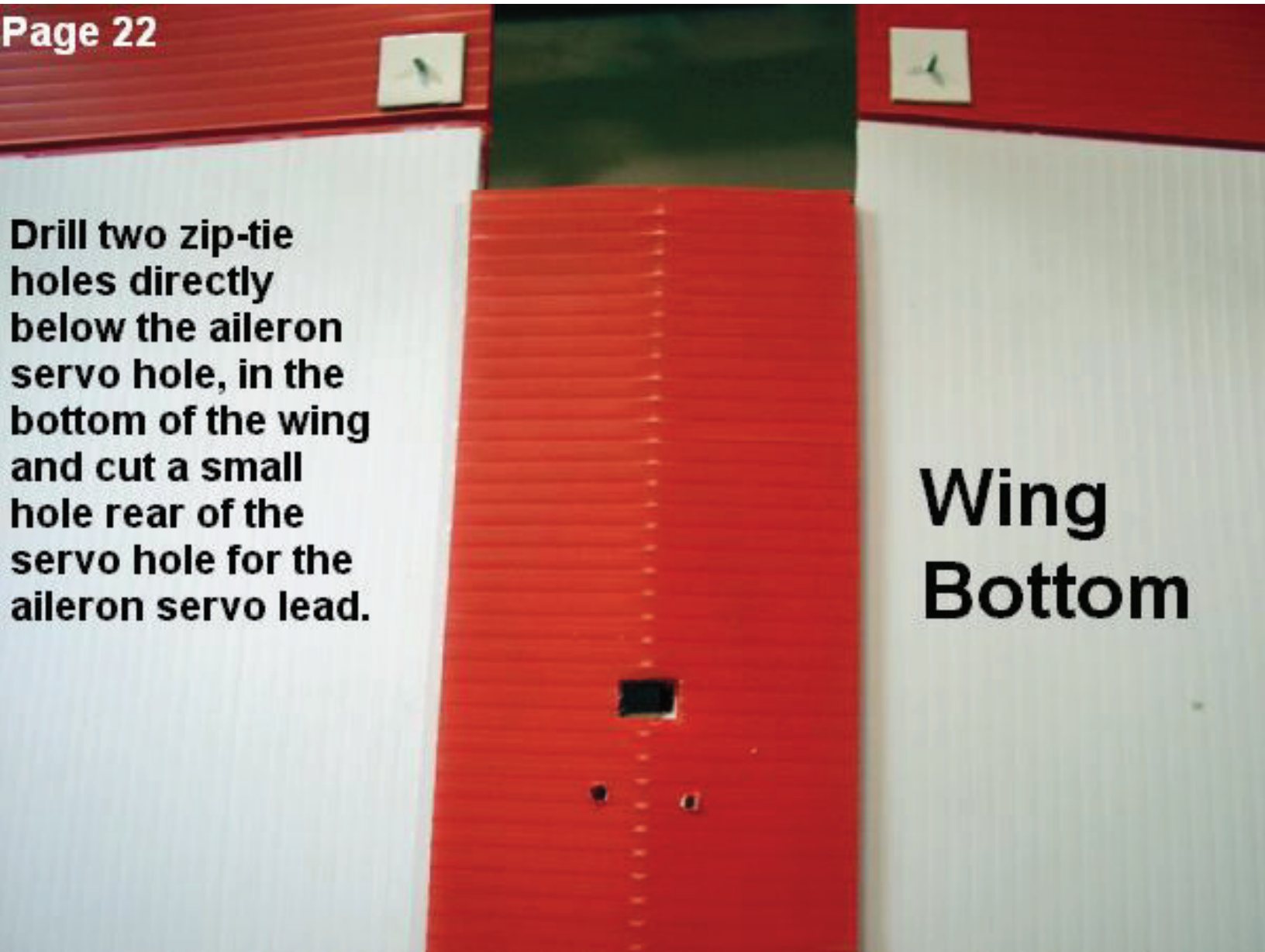

Install the aileron servo and secure with a Zip-tie through the bottom of the wing using the zip-tie doubler



**Wing
Bottom**

Shove coat hanger pieces
in leading and trailing edge
flutes of the wing wrap for
rubber band protection
Rigg ailerons for 3/4"
travel each way
(1 1/2" total)

Your ailerons must be
parallel to the fuselage
for neutral when
the wing is
strapped on



Now...GO
FLYING!!!